

Key 1:4

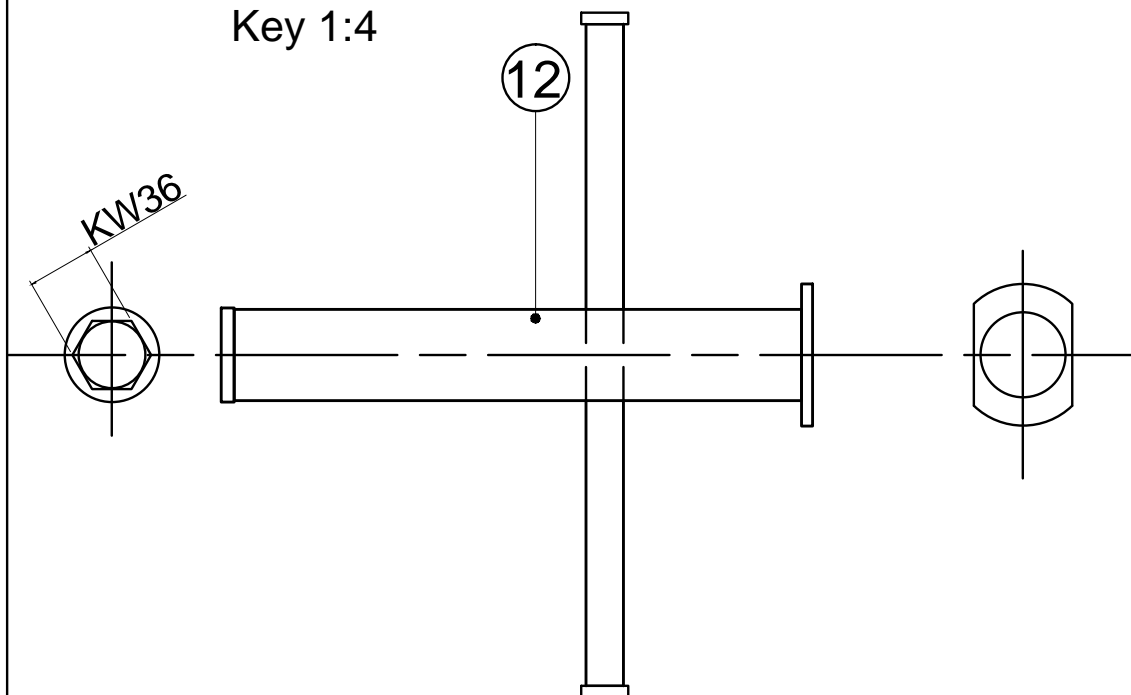

Details 1:2

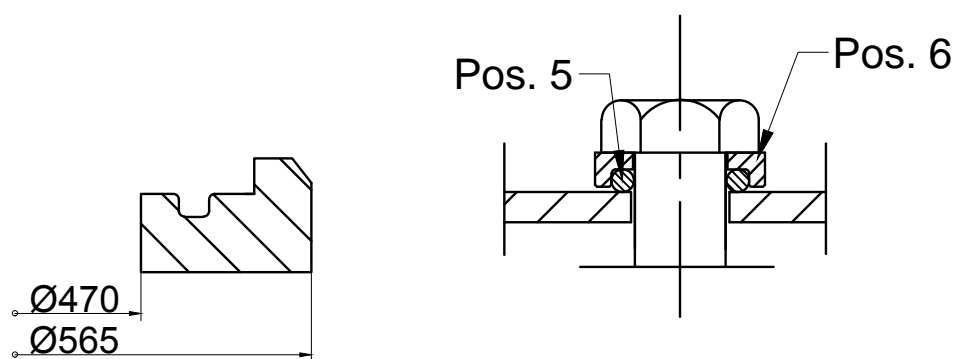

Details 1:3

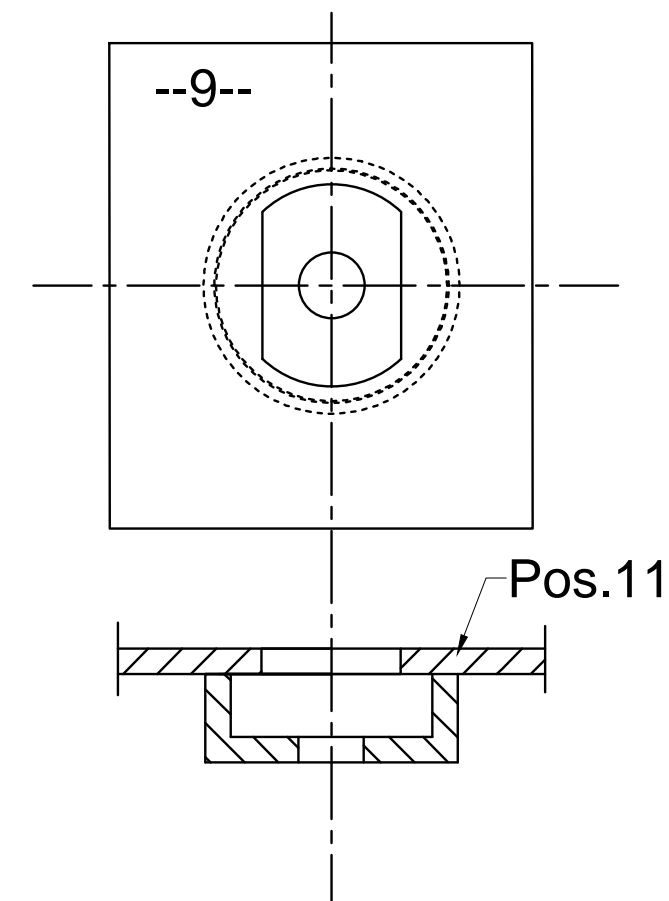

SUBJECT: STEEL MANHOLE C/O Ø470 TYPE CC FLUSH

12	1	KEY	ST.	
11	1	RECESSED BOLT HOUSING	Steel grade A	
10	1	THREAD BUS	ST.	
9	1	BRACKET	Steel grade A	
8	2	STRAP	Steel grade A	
7	1	O RING Ø 8MM	NEOPR.	OIL AND SEAW. RES.
6	1	LATHE RING Ø45x25x9	ST.	
5	1	O RING Ø36 x 24 x 6	NEOPR.	NBR 70 ±5° SHORE A
4	1	NYLOC NUT M24	INOX 316/A4	DIN 985
3	1	BOLT M24 x150	INOX 316/A4	DIN 933
2	1	RING	Steel grade A	
1	1	COVER	Steel grade A	

Pos.	Qty.	Description	Material	Remarks
------	------	-------------	----------	---------

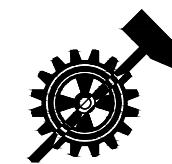
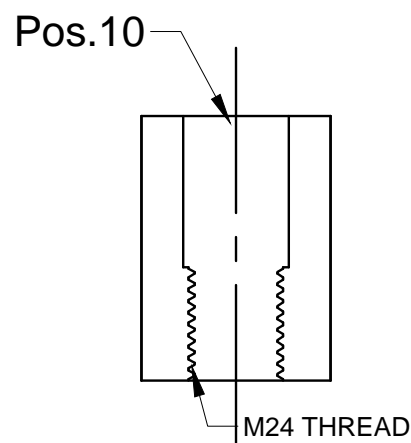
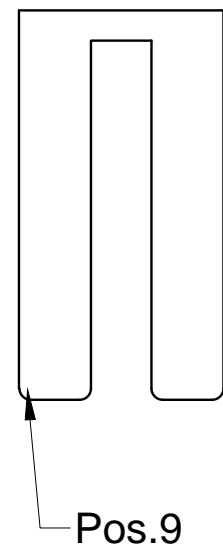
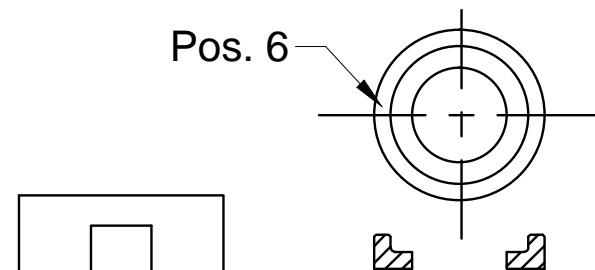

Schutte Metaal b.v.

Ampereweg 3 9503 GS Stadskanaal
telefoon 0599 620644 telfax 0599 617138

Drawingnumber:	Rev
MH-CC-470-1-FL	—
Format	Drawn : S.R.
A3	Date : 7-4-2014
	Scale: 1:(2)/3/4/5